

ROMAN WORKBENCHES

BEING A SHORT TREATISE ON BENCHES

FROM POMPEII, HERCULANEUM
& THE HOLY ROMAN EMPIRE

FOUNDED ON RESEARCH & HISTORICAL RECONSTRUCTIONS
WITH PRACTICAL APPLICATIONS CONCERNING

CONSTRUCTION, WORKHOLDING,
PLANING, SAWING, JOINERY &c.

FULLY & CLEARLY EXPLAINED

By CHRISTOPHER SCHWARZ

WITH 14 ILLUSTRATIONS BY
NICHOLAS MOEGLY



LOST ART PRESS, FORT MITCHELL, KENTUCKY, USA

Roman Workbenches

Published by Lost Art Press LLC in 2017
26 Greenbriar Ave., Fort Mitchell, KY 41017, USA
Web: <http://lostartpress.com>

Copyright © 2017 by Christopher Schwarz

Editor: Megan Fitzpatrick
Copy editor: Kara Gebhart Uhl
Research: Gorge Jonuschat, Suzanne Ellison, Jeff Burks
Illustrations: Nicholas Moegly, nicholasmoegly.com
Distribution: John Hoffman

All rights reserved

No part of this book may be reproduced in any form or by any electronic or mechanical means including information storage and retrieval systems without permission in writing from the publisher, except by a reviewer, who may quote brief passages in a review.

This book was printed and bound in the United States of America

Printed by Steam Whistle Letterpress (steamwhistlepress.com) in Newport, Ky., on a Vandercook 425 proofing press using polymer plates from Boxcar Press (boxcarpress.com). The paper is Mohawk Via Laid 70t. natural. The book was sewn and bound by Acme Binding in Charlestown, Mass. The font used throughout is Adobe Caslon Pro.

TABLE OF CONTENTS

Introduction	I
1. Pay No Attention to the Cow Costume	5
To the Ruins	6
The Pompeii Workbench	9
Meanwhile, at Herculaneum	10
A Pause to Praise Researchers	11
And Back to Herculaneum	13
Slabs of Wet Oak	14
Stop Start Stop	15
The Saalburg Workbench	16
Roman Holdfasts	17
2. Build the Herculaneum Workbench	19
True the Slab & Turn the Legs	19
Splayed Legs & the Easy Way Out	20
Assembly & Wedging	23
Trim the Legs	25
The Benchtop's Peg Holes / Use the Roman Workbench	26
Faces of Boards	27
Edges of Boards / Ends of Boards – Joinery	29
Other Helpers	30
3. 'Auf Wiedersehen' to Your Dollars	31
Enter the Gorge	34
Why so Quiet, Mr. Spoonwood?	35
Who Was Martin Löffelholz?	36
4. The 1505 Holy Roman Workbench	39
Five Slabs	40
Lay Out the Mortises	42
Tenons / Assembly / The Face Vise	44
The Vise Screws	45
The End Vise	46
Dog & Holdfast Holes / Details on Use	50
Conclusion	52
Sources	55
Acknowledgments	57

LIST OF ILLUSTRATIONS

<i>Fig. 1: Perdix at his bench</i>	4
<i>Fig. 2: The fresco at Herculaneum</i>	7
<i>Fig. 3: The Saalburg workbench</i>	14
<i>Fig. 4: Roman holdfast</i>	17
<i>Fig. 5: Construction details of the Herculaneum bench</i>	20
<i>Fig. 6: Use sightlines and resultant angles</i>	21
<i>Fig. 7: The half pencil</i>	24
<i>Fig. 8: Layout of peg holes</i>	25
<i>Fig. 9: Using pegs for planing edges</i>	28
<i>Fig. 10: The 1505 workbench and vise</i>	32
<i>Fig. 11: Northern Italian bench from the 14th century</i>	40
<i>Fig. 12: Plan view of the 1505 bench</i>	41
<i>Fig. 13: Elevation of the 1505 bench</i>	43
<i>Fig. 14: Metalwork for the 1505 bench</i>	47

Introduction

For many woodworkers, the workbench is an unwilling store-bought accomplice that we trick into doing our will. It's an appliance, such as a toaster oven or food processor, that we then press into doing the job of a "heat-treating furnace" or "mouse punisher."

As a result of these crappy commercial benches, every operation is a struggle. And when the woodworker sells his or her house, this sort of bench is often left behind to flummox its new owner.

Real workbenches adapt and anticipate your work. These flexible and simple forms were developed during the last 2,000 years when nothing was made of plastic and almost everything was made of wood. Wondrous and nearly forgotten, these alien benches are what keep me digging through old manuscripts and setting out to build "one more oddball workbench."

Since 1999, I have researched and built dozens of workbenches from different time periods to see if they work in a modern shop. From the 18th century, I built the monolithic "Roubo" workbench,¹ usually associated with French work. This bench opened my eyes as to how simplicity – many of these benches have no vises – could be used for complex furniture work.

During that research I also found an English variant (the "Nicholson") that performed all the operations of the Roubo workbench but required half the amount of lumber to build. It's a great bench for an island nation with limited forests.

But after building these workbenches, which I love, I realized I'd taken but a small step. There was still about 1,600 years of recorded history yet to explore.

¹ For more on French and English benches see "Workbenches: From Design & Theory to Construction & Use. Revised Edition" (Popular Woodworking Books).

So I went back as far as I could, to the Egyptians. That civilization invented most of the woodworking tools and joints we use today, but as far as I know its woodworkers didn't use a workbench (at least what we would consider a workbench). I've seen tomb drawings of boards lashed upright for ripping with a saw, and I've seen drawings of rocks with notches in them that could be used for holding the work with the assistance of the human body. But elevated strong worktables? Nope.

The first workbenches I'm aware of are from the excavations of two cities, Pompeii and Herculaneum, which were destroyed when Mount Vesuvius erupted in A.D. 79. Roman paintings (and engravings of paintings) show workbenches that are lightweight, simpler and (at times) far lower in height than a contemporary workbench.

These benches have fascinated me for years. I wondered: For how long was this form of workbench dominant? Could you perform complex joinery operations on it? Could you process boards for large-scale cabinetry? Could you work on the faces, edges and ends of boards with ease?

The only way to answer my questions was to build those benches.

So after gazing at about a dozen examples, I chose two workbenches for this book. The first is based on the A.D. 79 workbench shown at Herculaneum. It's an eight-legged beast with a holdfast. It's narrow (about 15") and only knee-high. This Roman-style bench had much to teach me about workholding because it shows what you can do with only a series of staggered holes, a few wooden pegs and two butt cheeks.

The second workbench in this book is what I consider the first "modern" bench. It has a Roman undercarriage much like the benches from Herculaneum and Pompeii. But its benchtop is revolutionary.

Martin Löffelholz, the man who likely drew this bench circa 1505, knew something about woodworking, wooden screws and escaping from his captors while urinating (more on that skill later). His two drawings of woodworking benches show a fully functional end vise, a series of dog holes and a twin-screw face vise. No butt cheeks needed.

While I know of a 14th-century Italian drawing of workbenches

with screw-driven faces vises, Löffelholz's bench is, as far as I know, the first workbench that has both a face vise and an end vise.

Both of these benches are far simpler than the workbenches that have been dominant for the last 300 years. The joinery to make them is but slightly more complex than drilling a hole and then driving a stick into said hole. The benches have no stretchers between their legs, no dovetails and no square mortise-and-tenon joints. I think that the only thing simpler than building one of these benches would be to find a workbench-shaped rock.

The following chapters tell a somewhat twisty tale of researching, building and using these workbenches. You'll hear how we flushed a bunch of money down the toilet. And about the time we thought we had caught a bench on fire. Oh, and I hope you aren't offended by Roman penises.

I hope this short book will grant you a few workholding tricks you can use in the shop, give you a peek at how ingenious the Romans were and – just maybe – convince you that the simplest of all workbenches can be used to build complex and beautiful pieces of furniture.



Figure 1: Perdix cuts a mortise at his bench, ignoring the "cow" behind him.

Pay No Attention to the Cow Costume

It's a bright summer day in Blue Hill, Maine, and I'm stalking around the house of the long-dead Jonathan Fisher to see what I can make of the man.

Fisher (1768-1847) was a Congregational minister who did wood-working on the side to make ends meet in early Maine. He had the kind of mechanical mind that thinks it's perfectly reasonable to build a wooden clock while attending Harvard. Or to hook up your windmill to your lathe.

But what interested me most during my afternoon visit to his residence was a crude and low bench that looked like it belonged in a barn. Like many vernacular pieces, this bench was made with "staked" construction. (Here's a Ph.D. in staked furniture: Drill three or four holes in a plank and ram a leg into each hole. *Fin.*)

Fisher's bench resembles hundreds of benches I've seen in castles and hovels all over the globe. But for some reason the pattern of holes in that particular bench's seat worked like alien crop circles on my brain. While at first glance the holes look like a naughty child had ventilated the seat out of boredom, I knew I had seen this pattern before.

I blurted out to no one in particular: "It's a Roman workbench."

It was obvious. The holes receive pegs that restrain planks of wood while you work them. I'd seen this pattern in 1950s Estonian texts, 15th-century drawings from the "Die Hausbücher der Nürnberger Zwölfbrüderstiftungen" collection, Pompeii, Herculaneum and at least a dozen other places throughout the time line of civilization. But it wasn't until seeing Fisher's bench that I connected the dots

between the Roman benches from A.D. 79 and the contemporary examples I'd stumbled upon.

This "Roman" bench form might have gotten its start in Rome. But like spaghetti, it can be found – with a local twist – in every culture and time period. I've seen it in modern-day Mexico equipped with loonily long vise screws projecting out the side (which I'm still trying to figure out). The Chinese still use a bench like this for all sorts of woodworking.

In other words, this style of bench has been around for at least 2,000 years. But modern woodworkers (myself included) were blind to it because to us a workbench is a 38"-tall strong worktable with stretchers, screw-driven vises and maybe a tool tray.

TO THE RUINS

After this encounter fermented for a few days, I took a serious look at the Roman workbench images from Pompeii and Herculaneum that had been hibernating on my hard drive. After some study, the biggest question in my mind was this: Were they just a low place to work for specialized operations, such as mortising, or could you perform complex joinery operations on them?

I started by examining the workbench painted on a wall in the House of the Vettii in Pompeii. The image itself is clear, the story being depicted in the painting is famous and the bench is as simple as you can get: four legs and a slab top.

For those who aren't familiar with Pompeii, the House of the Vettii is one of the most famous restored residences in the ruined city and attracts a lot of tourists, despite Priapus.

OK, let's pause before we discuss Priapus and the frescoes in the House of the Vettii. If you are someone who is upset by graphic sexual imagery you should shy away from Roman art. Put another way: If you think Cinemax shows dirty films, avoid Roman history and study something more conservative, such as 1970s porn.

The Roman attitude toward sexuality is absolutely unhinged compared to modern mores. While we might blush at the idea of an orgy, the Romans would clamor for more "man-on-goat" action.

I say all this because puritanical attitudes toward sex have occa-



Figure 2: The bench fresco from Herculaneum is mired in controversy.

sionally derailed scholarship on Roman culture. Many of the finds from Pompeii and Herculaneum that were deemed filthy were sequestered in the “Gabinetto Segreto” (the Secret Museum), a gallery in the Museo Archeologico Nazionale in Naples. This important archaeological gallery has been open only intermittently to the public since the objects were collected in 1821 (in 1849 they actually bricked over its entrance). Since 2000 it has been (generally) open to everyone.

So (OK, I’m serious now, prudes should stop reading) when you walk into the House of the Vettii in Pompeii you are greeted by an image of Priapus, a minor god of fertility and genitals, who is weighing his penis against a bag of coins. It’s a symbol of prosperity and fertility presented by the house’s owners, two freed slaves who had become quite wealthy.

And if you think that the skin show ends after you leave the entranceway, you would be wrong. Graphic depictions of sex are everywhere in the House of the Vettii and in Pompeii in general.

So you might feel some small relief after you pass through the main hall and courtyard where you can take a peek at a room called the “red oecus” – a formal dining room. In this room are some of the house’s best frescoes, including one of Daedalus presenting a cow costume that he built for Pasiphaë, the wife of King Minos.

In the extreme foreground of the image is Perdix (Daedalus’ nephew and apprentice), who is mortising a post or leg. His work is restrained with iron nails – Romans made tons of them – and it rests upon a low workbench with four splayed legs.

So there you have it: the beautiful Pasiphaë, Daedalus, a cow costume and young Perdix bashing out a mortise. But if you look closely at Perdix’s facial expression, you might see what I see. He’s oblivious to the scene behind him. He might, in fact, be trying to shut it out from his consciousness, like my kids holding their ears and chanting “nunga, nunga, nunga” to deny the call for bedtime.

So Perdix, why the thousand-yard stare? Don’t you approve of Pasiphaë’s cow costume?

Wait, why does Pasiphaë want a custom cow costume?

I’ll be honest here. My education in Greek and Roman myth was a bit lacking, so I asked researcher Suzanne Ellison to fill me in on the cow costume. She gave it to me in gentle terms, which I will reproduce here for the sensitive.

Pasiphaë had been cursed by Poseidon to have carnal affections for a particular bull. To satisfy those urges, she required a cow costume. Enter Daedalus, the inventor of carpentry, ship masts and glue. He built the cow costume and, after a magical night, Pasiphaë gave birth to the half-man, half-bull we call the Minotaur.²

So Perdix is keeping his eye on the mortise, or perhaps he is thinking about how he’s going to invent the saw, compass and chisel (before Daedalus tries to kill him and he turns into a partridge and...³). And we are left to ponder the bench he is sitting on.

² So Suzanne says I’m giving short shrift to the woman in the story and petitioned me to add: “Here’s a bit more about Pasiphaë’s story. She was a daughter of Helios, the Sun god. Minos was a son of Zeus. Poseidon and Zeus were often at loggerheads. When King Minos refused to offer a prized white bull in sacrifice to Poseidon, the sea god retaliated by cursing Pasiphaë and causing her to lust after the bull. The monstrous offspring that resulted, half-human and half-bull, was an abomination to Minos.”

THE POMPEII WORKBENCH

So here's what I see when I look at Perdix's workbench. It's about Sknee-high, so Perdix is sitting down. We don't see exactly what he is sitting on. It could be a stool, or perhaps he is supposed to be sitting on the work and the perspective is decidedly pre-perspective.

The work itself is restrained by at least two Roman nails that are pounded into the benchtop. And this is the first workholding tip for modern users: You can drive nails into your benchtop to secure the work. It's not my first choice when figuring out how to manage an odd-shaped workpiece. But I do it fairly regularly when I get backed into a corner. Sometimes you need the work secured to the bench with nothing sticking up above the work (if you use routers in your work I hope you are nodding in agreement; otherwise it's the cow costume for you).

This bench has four legs that are splayed out toward the corners of the benchtop. This is a fairly typical Roman representation of splay. Yes, I know it looks like the front legs lean left and the rear legs lean right. But after you look at a lot of early images, this is the way they represented rake and splay. The artist is, in my opinion, trying to represent both the elevation view and the profile view of the bench.

On the ground we have a bow drill and a sort of adze that could have been used for face- or edge-planing the work.

Then we have Perdix himself with a faraway look in his eye and a Roman hammer in his right hand.

When I first saw this image I assumed Perdix was using a mortising stool. It wasn't until I dove into untangling the image of a workbench from nearby Herculaneum that I decided Perdix was working at a workbench on which he could build almost anything.

3 Daedalus pushed Perdix from a tower. But Athena, who saw it happen, turned Perdix into a partridge before he hit the ground. Why a partridge? The bird lives in hedges, not in trees, and avoids flying too high.

MEANWHILE, AT HERCULANEUM

Herculaneum is about a 20-minute drive northwest of Pompeii and was destroyed by the same volcanic eruption in A.D. 79. While Herculaneum was wealthier than Pompeii and was rediscovered earlier than its more-famous neighbor, its contribution to our woodworking knowledge is somewhat flawed and uncertain.

Many of the artifacts from Herculaneum have disappeared due to poor excavation or conservation methods, including the image I am obsessed with: Two “erotes” (what we might call cupids) working on an eight-legged workbench that includes holes in the benchtop and a holdfast. It is the earliest image of a holdfast of which I am aware.

The original image of this woodworking scene was removed from the House of the Deer (Casa dei Cervi) in 1748. It was first deposited in the royal palace at Portici and what remains is now at the Museo Archeologico Nazionale di Napoli. For a variety of reasons (exposure to air and damp, haphazard storage and conservation methods and the way the fresco was made) by 1879 the workbench image had deteriorated to the point where the erotes had disappeared, according to Hugo Blümner’s book “Technology and Terminology of Trade and Art of the Greeks and Romans.” All we have left of the original painting are 18th-century copperplate engravings that were distributed all over Europe and England – many of them conflicting in their details.

So because we cannot see the original painting anymore, that leaves us with a question: How accurate are these 18th-century copperplate engravings?

It was the same sort of question that 18th-century researchers were asking when they saw the copperplate representations of the paintings and couldn’t afford to travel to Italy to view the originals. While visitors who saw the paintings in person were impressed, some foreign writers were skeptical.

“(T)hat the artists who were employed at Herculaneum, were of an inferior rank, is plain from their excelling chiefly in little subjects, as ornaments, animals &c.; a sure sign of a mediocrity of genius. These paintings were all executed upon the spot, and therefore probably not done by the best hands,” according to the first English

translation of “The Antiquities of Herculaneum” (1773) by Thomas Martyn and John Lettice.

But after studying the engravings and the original paintings that did survive, it’s clear that the Italian artists were meticulous in preserving the details of the paintings. Suzanne and I compared more than a half-dozen paintings that have survived to their engravings (all executed by the same 18th-century copperplate artist) and concluded that the engraver took almost no artistic liberties when representing the paintings.

The same, however, cannot be said for the Western European engravers who copied the Italian engravers. As the images of these paintings spread across Europe the details became muddied. In the example of our workbench painting, the bench lost its holdfast holes, it lost four legs, the saw moved and the holdfast disappeared.

Additionally, several poor translations of the Italian text describing the paintings amplified the misinformation.

How do I know all this? From hundreds of images that have been dug up by the researchers who help me.

A PAUSE TO PRAISE RESEARCHERS

As a lifelong journalist, I’m fairly good at digging through historical texts, making sense of them and then putting them to music with fart jokes. But my research – such as it is – would be less rich if I didn’t have the help of Suzanne Ellison and Jeff Burks.

I often refer to them as researchers for Lost Art Press. But that really doesn’t capture their doggedness. They are more like historical inquisitors. And here’s the funny thing: I barely know either of them.

Here’s what I do know. Jeff is a lifelong professional woodworker who lives in Connecticut. He became interested in old texts while working on a crew specializing in high-end trim carpentry. He watched them install difficult work – think curved and compound miters – through lots of trial, error and waste.

Jeff thought there might be a book at the library that could help them figure this stuff out. He was correct, and thus began his long relationship with the historical woodworking record, from collect-

ing 19th-century newspapers for the trades to learning the fundamentals of several languages so he could search European cultural archives that are online.

If you've been to a few woodworking shows, there's a chance you've been in the same room with him. It's unlikely, however, that you've met him. He rarely makes a scene and walks around with a camera near his waist, taking candid photos to record the tools and demonstrations.

Somehow during an event at *Popular Woodworking Magazine*, we had a conversation and I latched onto him like a saber-toothed information leech. During the years I've known him he's sent me thousands of images he's culled from online archives and books. Sometimes when I'm trapped on an airplane or at the doctor's office I'll pull out my laptop and start paging through them. There are at least 100 books I could write using those images. And Jeff finds more images all the time.

The funniest thing about Jeff is that many people don't believe he exists. They suggest that he's a figment of my frontal lobe. But I assure you he does exist. Other people can back me up.

Our other researcher is Suzanne Ellison. She's a retired analyst for a global cargo airline who has a longstanding love of art and history. She spends a lot of time engaging in the kind of research that few people do. First she translates the texts. Then she'll write or call anyone in the world to resolve her unanswered questions.

I first ran into Suzanne when she offered to write an index for my book "The Anarchist's Tool Chest." She's not a woodworker, but she had purchased a copy for her brother. After reading it, she sent me an email that said: "Hey, you need an index." I agreed, and she sent me an index that made me laugh out loud because it was a bit silly in places and referenced tube tops. I fell for her.

That was more than five years ago. We've been in constant contact ever since. Oddly, I've met her in person only once – for breakfast in Maryland after I'd finished teaching a class. It was a fun morning, and I ended up with a lot of crab memorabilia.

While Jeff is like a fisherman who works with big nets, Suzanne is like a French fur trapper. She is relentless in following a trail until she finds the image, the date or the academic she needs (who she

then charms into turning over his or her research). Like Jeff, she moves easily between Italian, French, German and even some of the languages in the low countries.

I don't deserve to work with either of them. They refuse to be paid for their research, so I sometimes send them boxes of stuff. Suzanne is gracious and responds with a nice handwritten "thank you" note. Sometimes I wonder if Jeff throws my boxes in the dumpster.

AND BACK TO HERCULANEUM

So the workbench from Herculaneum – Suzanne calls it the "falegname" (Italian for "carpenter or joiner") fresco – is troubling. The original painting is kaput. But the engravings of the falegname fresco are so tantalizing that I couldn't ignore them.

At some point during the four years we worked on this book, Suzanne and I decided to take the early Italian engravers at their word. We accepted that the workbench in the falegname fresco has eight legs. It has a holdfast and a series of holdfast holes. And the frame saw makes no sense – the blade shouldn't be in the middle of the frame. (But I'm going to leave this detail to someone who wants to write a monograph on frame saws.)

This wasn't an easy decision to make. A lot has been written about this woodworking scene, and some educated people contend that the image doesn't depict a workbench. Instead, we're looking at two sawhorses. Some work is placed on top of the sawhorses. Yes, there is a holdfast. But it's really a depiction of two sawbenches (or sawbucks).

Because we now know a lot more about low benches in Naples, Saalburg, Estonia and China (to name a few) I can safely disagree. It's a bench with eight legs (why eight legs? Who knows). And there's a piece of work on top of the bench.

So I decided to build the Herculaneum bench because it offered more unanswered questions than the one pictured at Pompeii. And hey, I'd be the first person in my neighborhood to build an eight-legged bench.

The day I made that decision, I started sending emails to North Carolina.

SLABS OF WET OAK

Though I'm surrounded by hardwood forests in Kentucky, it's been difficult to find thick slabs of wood that are wide and long enough for building ancient workbenches. (I have since found a local source of slabs, which proves that you simply need to keep looking – it took me only 21 years.)

But in early 2016 I needed slabs of a certain size that would be ready at a certain time. So I called Will Myers.

Will runs an automotive body shop in North Carolina during the day and is an enthusiastic woodworker for the rest of his waking hours. I first met Will when he showed up at a class I was teaching at Roy Underhill's school, and he was hauling a much-needed load of pure beeswax he had harvested.

Will and I worked together at both sessions of the bench-building event in Georgia called the French Oak Roubo Project. We're both Southerners. We both drink beer. So I do not need to say any more about our relationship.

Oh, I also knew that Will knew a sawyer who was happy to saw big slabs of oak – up to 6" x 24" x 8' – for a reasonable price. After some back-and-forth, Will agreed to work with the sawyer, Lesley

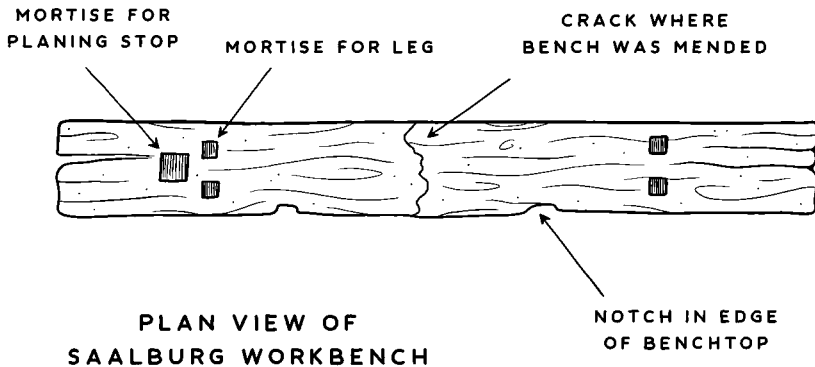

Figure 3: The Saalburg workbench is the earliest surviving bench known.

Caudle, to cut and dry some slabs for both workbenches in this book.

Will insisted on using red oak because it is easier to dry than white oak and many other species. The fact that red oak dries without massive distortions or checks is the nicest thing I can say about it. Red oak is the “has a great salad bar” or “but is a really great dancer” of the hardwood world.

The slab Will and Lesley cut and dried for the Herculaneum bench measured about 4" x 16" x 85". It was bone dry after a spell in Will's homemade kiln. (The slab for the other bench in this book, however, refused to dry. More on that slab later on in the book.)

Will and Lesley also cut some red oak stock for the bench's legs. But when I came to pick up the wood, I forgot to throw it in my rented van. So instead I used some white oak left over from other projects for the eight legs. The legs ended up 2" in diameter x 22" long, so you can use 8/4 rough stock for your legs and get the same result.

STOP START STOP

When I build projects such as the Herculaneum workbench, I don't stick to a strict construction drawing – I stick to the historical images. I start with a good sketch and a cutting list. But as I take each step forward in building the project I compare my results to the images I have on hand.

Does this look right? Am I off the rails?

I know I'm an odd sight to the people who walk by my shop window, but I spend hours at my bench staring at historical images I've printed out. I draw on the printouts. I scrawl my questions in the margins. Then, when there's nothing left to argue about in my head, I pick up my brace and walk to the waiting slab to make one quick hole that will determine the next two weeks of work.

As I think you'll see, it's the holes in this bench that pose the most questions and offer the most insight into early woodworking practices.

THE SAALBURG WORKBENCH

Not much Roman woodwork has survived – it's been a long time since *Pax Romana*. But thanks to excavations at a Roman fort at Saalburg, which is just north of Frankfurt, we might have a look at a surviving Roman workbench top.

The fort was initially investigated in the mid-19th century then rebuilt between 1897 and 1907 as an open-air museum.

The museum houses many Roman artifacts, including wood-working tools, plus (surprisingly) Roman objects made from wood and leather, which were preserved in wells at the fort.

I first learned about this benchtop from W.L. Goodman's "The History of Woodworking Tools" (1964), which quoted work by German woodworking historian Josef M. Greber.

Greber drew an oak benchtop measuring 4" x 12-1/4" x 101-1/2". It has four mortises for splayed legs, a mortise for a planing stop and two notches on one long edge that could be there for a variety of reasons. My suspicion is they were used like a brake is used on primitive workbenches. The worker would place the work in the notch and wedge it in place to saw a tenon, for example.

The slope of the mortises in the top suggest the bench was low and used while sitting down. In fact, at some point the museum had added four square legs to the original top, which confirms it was almost certainly a low workbench.

As far as I know this is the oldest surviving workbench in the Western world, and thanks to photographs and museum accounts we also know it was a well-used item.

Side note: Two other similar planks were found at Saalburg, according to the museum's records, though they did not have the mortises and notches mentioned above. The second top is 2-3/4" x 13-3/4" x 84-5/8". The third top is 2-3/8" x 14-1/8" x 115".⁴

⁴ Scholarship suggests these additional plank might have been intended to be workbenches. Perhaps the woodworker who made the fully functional workbench was going to use the additional planks for benches in his or her shop. Or was going to sell them to other artisans.

ROMAN HOLDFASTS

Roman workbenches don't have much in the way of complicated workholding schemes, usually just a series of holes. These holes could be for pegs (as shown in some Estonian workbenches), holdfasts (as shown in the Herculaneum engraving) or both.

The holdfast in the Herculaneum engraving has always fascinated me. It looks like a shepherd's crook but doesn't terminate with a pad on the end of its beak like a modern holdfast.

When I show the image to fellow woodworkers, most don't think the holdfast will work. Without the pad, they say, the thing will bounce out of its hole and fail to grab the work.

I have found that holdfasts are the ultimate wood-working magic trick. The first time anyone encounters any holdfast of any shape, they're skeptical the thing will grip the work with just a tap over the shaft. Because of our species' natural holdfast skepticism, I had high hopes that the Herculaneum

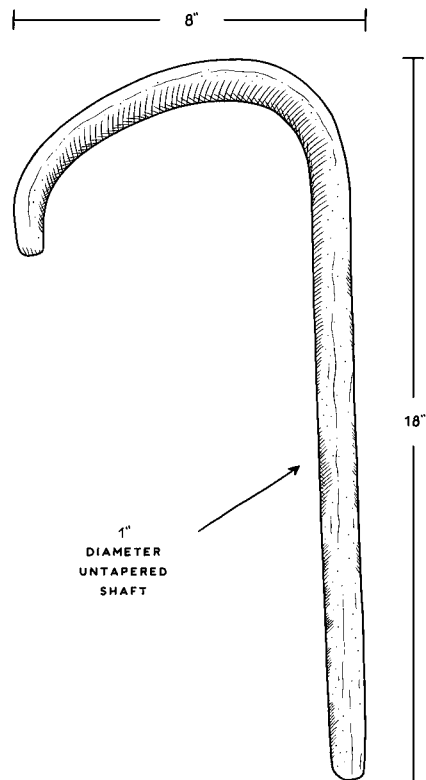

Figure 4: This Roman holdfast has an untapered shaft and a simple bend.

holdfast would function just fine.

After discussing the tool with blacksmith Peter Ross, who has made many holdfasts during his career, he agreed to make one. I sent him a sketch of the shape based on the engraving and asked him to make it from wrought iron and with a 1"-diameter untapered shaft.

Why not taper the shaft? I have found holdfasts work better with a straight, untapered shaft. And as Ross said to me: "Most old ones I've seen don't have tapered shafts."

The Roman holdfast that Ross made is, like all old technology, a surprise. It works really well and can hold pieces that are flat or tapered (a task that a holdfast with a pad can struggle with).

It has two quirks. First, you must find its sweet spot. Unlike a modern holdfast, the Roman form won't set if you strike it over the shaft. The sweet spot is a wee bit forward of the apex of the curve. Releasing its grip, however, is the same as a modern holdfast: Strike the back of the shaft.

The other quirk is that it marks the wood below it – remarkably. And the mark looks exactly like a belly button. This mark is no big deal because traditional practice is to always place a sacrificial scrap between the pad and the work. I've seen a lot of people try to cheat by polishing the pad or adding a leather bit to the pad to avoid denting a scrap of wood.

I think this is risky behavior. Nothing protects as well as a wooden scrap, and most woodworkers have no shortage of wooden scraps. So why try to be so tricky?

After using this holdfast for about six months I had to ask myself the question: Why did this holdfast form disappear? After all, Ross said it was considerably easier to make than a modern holdfast because the Roman tool lacks the sharp turn between the shaft and the beak. And there is no pad or taper to make.

My best guess is that the modern holdfast replaced its ancestor because it's simpler to set and has a more graceful look about it.

Build the Herculaneum Workbench

The act of building the workbench from Herculaneum is simple. You true up a slab. You make eight legs. You drill eight holes in the slab. You drive in the legs and wedge them.

The real challenge is, instead, what happens next: using this low bench for making furniture.

I don't want to assume, however, that making this workbench is easy. If it were, you would have already built one and skipped this part of the book, right? There are compound angles, tapered legs, wedges and other details to manage. So let's start at the beginning of the process and walk through every step like it's important (it is), especially if you ever want to build chairs.

TRUE THE SLAB & TURN THE LEGS

Pick your bench's width. Start at 15" or so and work your way down in width until it doesn't feel like the wood is a speculum when you perch upon it.

My bench began as a slab of wood that I could straddle – 3" x 15" x 85". I have gangly praying-mantis legs that can grip a 15"-wide slab. I am not proud of this; it's just the way I came from the factory.

Plane one face of the slab flat. Then work one edge of your slab so it's flat and straight. Call this the "true edge." The true edge should end up 90° to both faces of the work. Once you get that under control, flatten the other face of the slab and straighten the other edge of the slab.

What about the ends of the slab? Forget them.

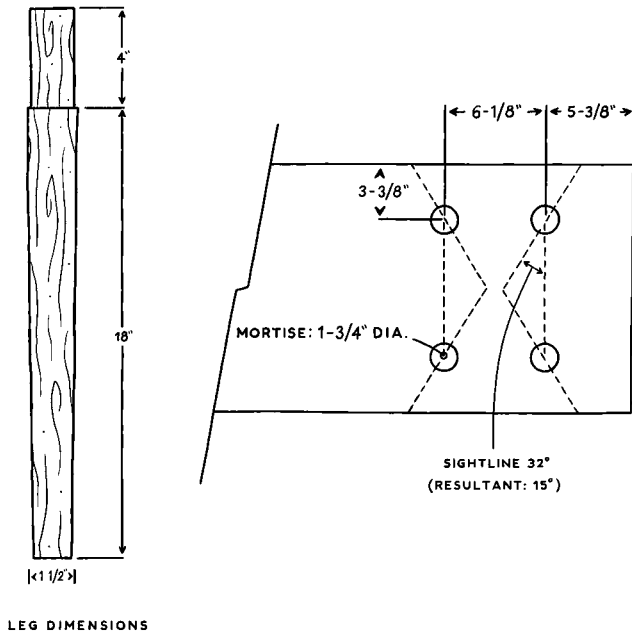

Figure 5: Construction details of the workbench.

I have a lathe, and I can turn. So I make life easier at every turn (sorry) with this machine. If you don't have a lathe, make the legs with a drawknife or spokeshave. The legs don't have to be round.

My legs are tapered cones with tenons at the thick ends. The legs start at 2" at their thickest, are 22" long and taper to 1-1/2" at the feet. The 1-3/4"-diameter tenon on the end of each leg is 4" long (this dimension depends on the thickness of your benchtop). The details are in the drawing above. The bench will end up as tall as the distance from the bottom of your kneecap to the floor. But don't worry about height now – you'll cut the legs to final length later.

SPLAYED LEGS & THE EASY WAY OUT

The legs of this bench have both rake and splay, so the mortise is drilled at a compound angle. Did you just consider closing this

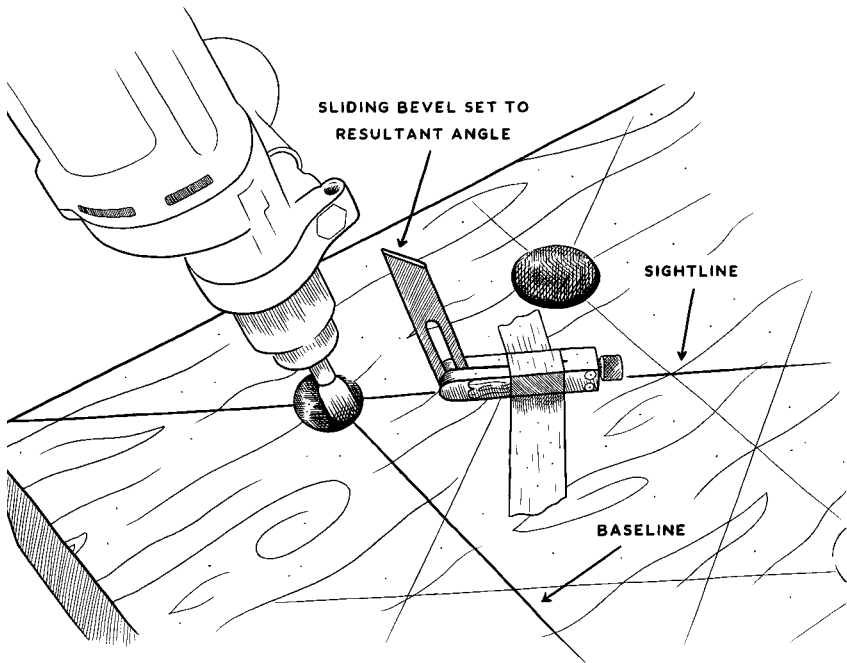

Figure 6: Use sightlines and resultant angles to bore the mortises.

book? About 20 years ago I would have had that urge.

Compound-angle joinery is easy. The trigonometry to describe it is what hurts your membrane. I'm going to describe how to lay out and execute the compound-angle mortises with no math. All you need to do is draw a few lines on the underside of the benchtop, set a sliding bevel gauge to one angle then drill a hole that matches that angle on the sliding bevel. It really is that easy.

When we think about a compound angle, we usually try to break it down into two separate angles that push the leg off both an X axis and a Y axis. We think we have two angles – tilt the leg X° off the X axis, then tilt it Y° off the Y axis. If you follow these two angles

simultaneously you will drill the correct compound-angle hole.

And this is Minotaur shit.

There's a better way to drill a compound angle and it uses a "sightline" and a "resultant angle." The sightline is an imaginary line that runs through the leg. The following explanation is a bit daft, but it works. I pretend that the sightline is a laser beam that shoots out of my eye when the leg appears to be sticking up at 90° to my laser eye. That angle – when the leg appears to be 90° – is the sightline.

(Side note: Please try this with any chair in your house. Turn it upside down and rotate the seat until the leg looks like it's at 90° to the seat. That line between your eye and the leg represents the sightline.)

Then we tilt the leg toward the eye or away from the eye. That is the resultant angle of this equation. So if we can find the sightline (when the leg appears vertical to our eye) then we can find the resultant angle.

I do this by making half-scale models of the project using MDF and wire hangers. But I'm getting ahead of myself. Really, the simplest thing to do here is to give you the directions for drawing out the sightline then supply the resultant angle for your sliding bevel gauge. (If you want a full education in calculating sightlines and resultants without numbers, check out "The Anarchist's Design Book." Here ends the commercial.)

Use the illustrations on the previous pages to lay out the position of the eight mortises in the underside of the benchtop. (If your slab is narrower, you'll have to adjust your layout.) As you can see, the legs are in pairs – the outside pairs and the inside pairs. Draw a line (as shown) to join the two mortises for the outside pairs, then the inside pairs. Let's call these lines the "baselines."

Use a protractor to create lines that are 32° off the baselines and that intersect the mortises. These 32° lines will create a squat triangle and are your sightlines. You are almost ready to drill.

Fetch your sliding bevel gauge. Use a protractor to set the bevel to 15° off vertical. Tape the stock of the bevel gauge to the sightline with the blade poking up in the direction the leg should go. Clamp a backer board to the top of the benchtop where the mortise will emerge to prevent splintering. Chuck a $1\text{-}3/4$ "-diameter bit in your

drill or brace and position it so it is in line with the sightline and tilted at 15° to match your sliding bevel. Drill the mortise.

Drill all eight mortises. Then test the tenons on the legs to make sure they fit. Now is a good time to assign each tenon to a mortise by numbering or lettering your parts. All the legs should be interchangeable, but I'd hate to discover they weren't when everything is covered in glue.

ASSEMBLY & WEDGING

Like a Windsor chair, you should wedge the bench's tenons in place. I make wedges from $1\text{-}3/4$ "-thick oak. I saw them out so they are about $2\text{-}1/4$ " long and slope 4° to a fine point. I recommend you make about three times as many wedges as you need because things go wrong. For starters: Wedges split, their tips get mushed and they bounce out of the tenon at times.

After sawing out your wedges, you have two choices about how to drive them in. You can be a daredevil: Glue the tenons into their mortises, then use a wide chisel to split the tenon to receive the wedge. This works well if your tenons are a loose fit in their mortises. If the tenons fit tightly, however, *bon chance* with this hot-dogging technique.

The other path is to saw a 2"-deep kerf into each tenon with a handsaw. The kerf makes it easier to insert the tenon into its mortise. And the kerf makes it easier to start the wedge. All told, it took me only 15 minutes to kerf the eight tenons. Debating whether or not to do it can take considerably longer.

Paint hide glue on the inside of the mortises and on the tenons. Push each leg into its mortise then rotate each leg until its kerf is perpendicular to the grain of the benchtop.

Paint the wedges with glue and drive them in with a hand sledge or chunky hammer – now is not the time for half measures. Hit each wedge until it stops moving. When your blow has no effect, you're done.

After the glue dries, trim the wedges and tenons flush with a saw. Then plane the benchtop flat.

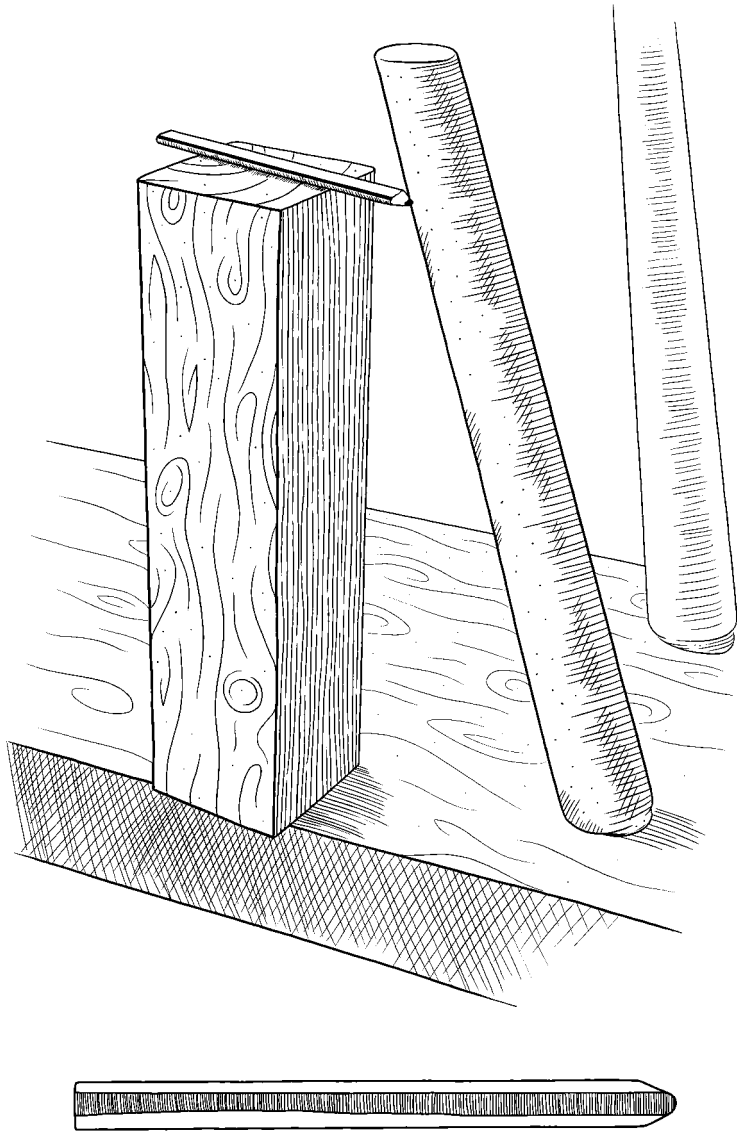

DETAIL OF HALF PENCIL

Figure 7: A pencil planed in half can help level the legs with ease.

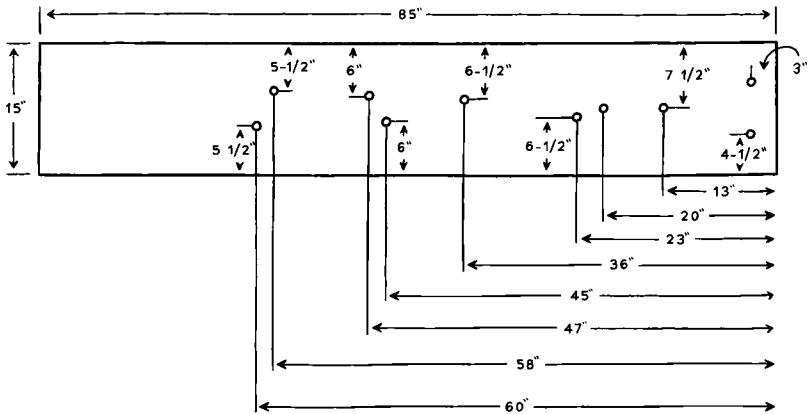

Figure 8: The suggested layout for peg holes in the low Roman workbench.

TRIM THE LEGS

First flip your bench upside down so it looks like a dead spider-pig. Leveling the feet of the bench is like leveling the feet of a chair. First you have to decide how tall the bench should be. I recommend it come to just below your kneecap. This height will make it comfortable for sitting and working.

Once you know this dimension (let's say it's 17"), then subtract the thickness of the benchtop (3") to get the result: 14". And that's the length of the magic 2x4 that will mark your legs.

Cut a 4x4 to your magic length. Then plane a carpenter's pencil in half – yes, I'm serious here. This is what we call the "half-pencil" and it is good. Place the half-pencil on top of the magic 4x4 and set the 4x4 on the underside of the benchtop. Mark the legs to their final length.

Then set the bench on its side and saw all the legs to length. Ease the sharp corners of the feet with a rasp.

THE BENCHTOP'S PEG HOLES

The benchtop is pierced with a series of 1"-diameter holes that, with the help of stakes or pegs, restrain the work for sawing and planing. The location of these holes is not arbitrary (though I encourage you to try other arrangements). The hole pattern shown here is based on studying old benches and messing with them.

In the next section of this chapter I'll show how these holes work. So you can drill them (or pretend to drill them) and read on to the next section.

After decades of using a brace (I think I was 12 when I first used my dad's Craftsman brace) I find it easy to drill a perpendicular hole. If you aren't confident, I recommend you make a drilling jig that makes it easier. The first step is to drill a perfectly plumb 1" hole through the width of a 2x4. Then use that perfect hole as a guide for the other holes.

Clamp the 2x4 to your benchtop and use the plumb hole to guide your bit as you drill all the holes in the benchtop as shown in the illustration.

After you drill all the holes, tidy up your work. Break any sharp edges and apply a few coats of boiled linseed oil to the workbench. While the finish is drying, take some 1-1/4" dowels and shave one end of each so it tapers to 1". These pegs will restrain your work; having several at different lengths – from 5" to 12" – will do the trick. But you'll figure this out after you read the next bit.

USE THE ROMAN WORKBENCH

When I first started experimenting with this bench, the pattern of holes seemed random. But after working with these benches for months the holes make sense. Some holes restrain the work from shooting forward; others restrain it from flying sideways.

What's also important is what you put into these holes. A modern woodworker (such as myself) might assume that you would put low bench dogs into these holes. But what if you had a bunch of tapered stakes of different heights to put into the holes? Would that

change the workholding? (Spoiler alert: yes.)

Here's how I tackled all the operations that a furniture maker attempts on a workbench.

FACES OF BOARDS

Working the faces of boards – whether with a plane or saw – is the most straightforward operation on this low Roman bench. Let's dispense with the sawing first.

Crosscutting and ripping on a Roman bench is luxurious. For most of my adult life, I've worked with two or three sawbenches to rip and crosscut stock. While sawbenches are portable and versatile, I move them (or my work) around a lot to keep the important bits supported during a saw cut.

When ripping you have to push the work backward or forward on the sawbenches (depending on your style of ripping) to ensure the waste doesn't split off because it's unsupported. For crosscutting you have a slightly different dance, moving the sawbenches to prevent the waste from breaking off or pinching your saw in the kerf.

The Roman bench is essentially two conjoined sawbenches, so you have an enormous amount of support below your work for rips and crosscuts. I occasionally bring in a sawbench or shop stool to help with crosscutting long pieces, but that's rare.

Planing faces is also spectacularly simple. Most of the benches I've observed in the wild or in paintings have one or two stops at the end of the bench that work much like a traditional planing stop on a workbench. You knock the stops up or down depending on the thickness of your work.

But what about longer stock? Well once you get into boards that are longer than your arms can reach, then you start to sit on the work. With workpieces longer than 40" I begin by processing the stock by sitting close to the planing stops. When that section is planed I scoot backward about 3' and repeat the process.

Planing boards' faces is one of the times the four extra legs on my bench come in handy. When working close to the planing stop my feet wrap themselves around the legs to help pull me forward into the cut. This reduces the planing effort.

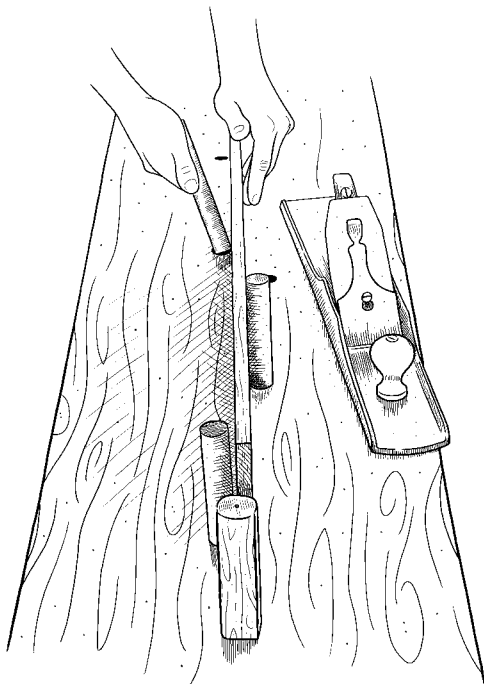

Figure 9: Use pegs to support the board while planing edges.

Likewise, when planing long boards, my feet push against the back legs to help me resist the plane's inertia in a heavy cut.

Traversing boards with a fore plane is also fairly easy with the low bench. You brace the work against the planing stop, then use your knees to lock everything tight. Finally, you plane the area between your legs. An outboard sawbench helps to support long stock or when you are at the beginning or end of a particular board.

Mortising and other operations on the faces of boards (dadoing) use some combination of the above techniques. For mortising, sit on the work like Perdix does in the painting. For dadoing, saw the sides of the dado with a saw like you are crosscutting. Waste away most of the stock with a chisel. Then remove the waste with a router plane like you are traversing the work (lock the board against the

planing stops with your knees). If you use dado planes, then the operation is exactly like traversing the work with a fore plane.

EDGES OF BOARDS

I was skeptical of how easy it would be to plane the edges of boards. For short or narrow boards, it was easy to work against a single planing stop – much like I do on a high bench.

But for wide boards it seemed easy to tip the work over, especially when trying to correct an edge with a cambered iron. Once again, “Woodworking in Estonia” gave me an important clue.

In the book, woodworkers are shown edge-planing boards against a planing stop with a peg supporting the work from one side. This single peg stabilizes the work while planing, but only when pushing mildly against the peg on the side – the work can still flip out of position with mild lateral pressure.

So I added a peg on the other face of the board. This second peg supports the board from both faces and allows you to plane the board much like it is in a vise. The board resists lateral pressure so you can correct an out-of-square edge with ease.

This small discovery led to other “a-ha” moments concerning the pattern of holes on the benchtop. The holes frequently spread out as they moved farther away from the planing stop. After using the bench for a while, this made sense. As you switched to wider and longer stock, these holes supported wider and longer boards.

While the above guidelines are a good place to start when working with a low bench, after a while you just begin to use whatever holes are open for a particular operation. Typically, I’ll put a board on edge on the benchtop and look for a series of three holes that will keep it secure: one hole at the end of the board and two holes to the sides of the board to keep it from tipping over. Any three holes will do.

ENDS OF BOARDS – JOINERY

Even though I’ve been surprised a thousand times by the ingenuity of early workholding, I really wasn’t sure that cutting

dovetails and tenons on a low bench was going to feel natural. But after a few joints, it did.

For making dovetails and tenons, you approach the work like you are crosscutting or ripping it on a sawbench. Place the work on the benchtop, hold it down with one knee and saw away.

When I first started experimenting with the Roman bench and sawing dovetails I cut the tails first, but Roy Underhill pointed out that sawing pins first was the better method for this bench. Why? Transferring the shape of one board to the other.

If you cut the tails first, then transferring the shape to the pin board puts your workpieces high in the air, balancing the two boards while trying to make your marks. If you cut the pins first, however, the transfer is easy. Lay your tail board flat on the benchtop. Place the pin board on the end of the tail board and shift things around until they match. Mark the tails.

Somewhere, Frank Klausz is smiling because of this detail. I'm a tails-first guy, so this is no easy thing to admit.

Tenoning is similar. Saw the cheeks until you hit your baseline. Flip the stock over to finish the cut on the other side. Saw the shoulders like you are crosscutting. It's awkward at first, but you'll get over it.

OTHER HELPERS

While I've been using my knees and buttocks to hold my work, the Romans had other options. Because of the Herculaneum painting we know the Romans had holdfasts. So you can use a holdfast to restrain your work while tenoning, mortising or carving. Also good to know: The Romans had iron planing stops that were similar to the planing stops from A.J. Roubo's "l'Art du menuisier." So you can equip your bench with a big planing stop if you like. Once final note: Remember that the Romans also had high workbenches. A 1st-century Roman stone carving from Metz, France, shows woodworkers planing on high benches much like we do today.

CHAPTER 3

‘Auf Wiedersehen’ to Your Dollars

My research on the 1505 workbench drawn by Martin Löffelholz began when I saw a sketch of it in “Das Werkzeug Des Schreiners und Drechslers” (“The Tools of the Woodworkers and Turner”) by Günther Heine.

The bench also shows up in Scott Landis’s “The Workbench Book” (Taunton Press), which is where most bench nerds have spotted it.

It’s a shocking image for 1505: a staked workbench complete with a twin-screw face vise, a screw-driven wagon vise and a series of dogs.

To me, that image represents the 16th-century woodworker flipping the bird to all future centuries. By 1505 (and perhaps earlier), engineering minds had created the modern workbench – 200 years before it became commonplace.

But who was Löffelholz? Did he invent the bench or see it in a workshop? How did Löffelholz describe the bench and its mechanisms?

At the time I saw the image, there was no internet to speak of. And I couldn’t learn much about Löffelholz in our local library or find a copy of the 1505 text that the image came from.

So during the last 15 years, “Martin Löffelholz” became one of the things I would idly search for during late nights with my laptop. I hoped that someone would scan something in some European library, and that I would get lucky. In early 2016, that actually happened.

I found a document in the digital archives at Jagiellonian Univer-

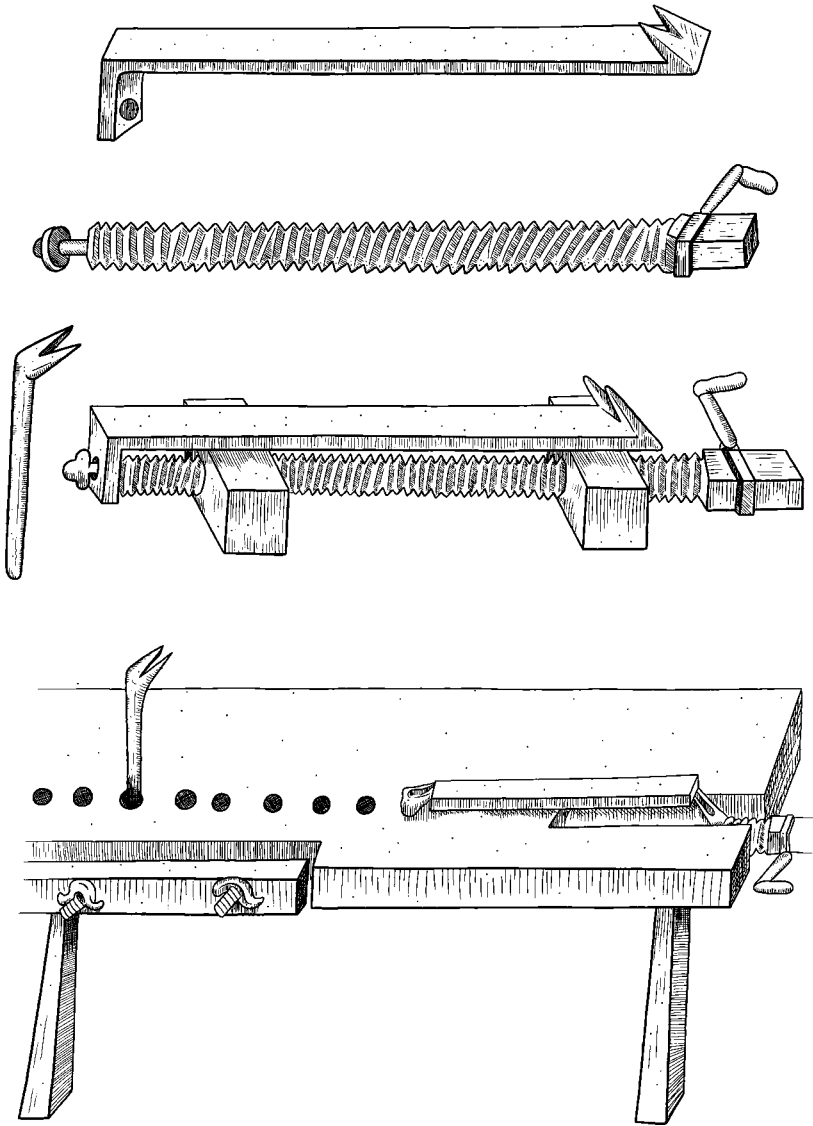

Figure 10: The drawings of the 1505 bench and vise.

sity in Kraków, Poland, titled: "Löffelholz-Kodex..." (Löffelholz Codex: Illustrations and descriptions of all kinds of hand tools, torture instruments, hunting devices, weapons ... and other items of entertainment"). Jagiellonian University indicates the original codex is in its possession, though I do not know how it arrived there. A 1933 source indicated it was in the Berlin State Library.

In any case, there it was: 82 images of a codex (a codex is an ancient handwritten form of book) filled with color illustrations and descriptions of tools, torture devices, office equipment and two workbenches. In addition to the two workbenches, which are similar, Löffelholz drew a separate page that illustrated the inner workings of the wagon vise.

I squealed.

As exciting as the drawings were, I was more intrigued by the text. Each drawing was accompanied by tightly written script, presumably describing the items on the page. Here, finally, was an explanation of the workbenches and vises in the codex.

My German language skills are limited to ordering Weissbier at a Gasthaus, so I needed help. Luckily, a fair number of German speakers read my blogs, despite the language obstacle. (Finally, the Schwarz name pays off.)

I received dozens of offers of help. After reading their qualifications I selected a handful of people who seemed promising – they were woodworkers, perhaps did some translating for their jobs and were enthusiastic.

I sent the codex to all of them and asked: What do you think?

All of them gave me the same answer: I cannot read Löffelholz's handwriting.

I had braced myself for this reply. I myself had tried to make sense of the handwriting on the page next to the workbench. To my eye, the script looked more like a venereal disease under a microscope than words.

So now I had to first find someone who could read the handwriting and transcribe it. Then translate it. And then I might know what Löffelholz wrote about workbenches in 1505.

Lucky for me, one of the Germans who volunteered to help me was Göрге "doesn't take Nein for an answer" Jonuschat.

ENTER THE GÖRGE

Görge is an architect, woodworker, tinkerer and someone who always seeks to be busy with interesting projects. “If there’s nothing to do, I get bored easily – frankly speaking,” he wrote to me. “I can hardly just sit around.”

So between architecture projects, Görge looked for someone who could read 16th-century handwriting. He had no luck in Poland with the university that owns the codex, but he eventually found Dr. Walter Bauernfeind at Stadtarchiv Nürnberg (the City Archives at Nürnberg).

After some negotiations and persistently polite letters from Görge, Dr. Bauernfeind and Helge Weingärtner kindly agreed to transcribe sections of the codex for an hourly fee. Transcribing the entire codex would have been a massive project and cost more than a new automobile. So Görge went through the codex and isolated the sections related to woodworking, tools and carpentry.

Note that as a result of this process, we saved thousands of American dollars (thank you, Görge!), but we also missed out on a 1505 love potion as a result (Boo!). Such is woodworking journalism.

In April 2016, Görge sent me an enormous electronic document that was the result of years of searching, months of investigating and weeks of transcribing and translating. It’s a fascinating 154-page document that reflects Dr. Bauernfeind’s lifelong mastery of early German text and Görge’s dedication to untangling that early German into a translation I could read. But there’s not a single word about the workbenches.

Because it hurts, let me repeat that: After untold hours of research and more than a thousand dollars spent, we had nothing. Every other image in the codex had a caption we could translate and turn into a master’s thesis.

Löffelholz went into great detail on how to keep wolves from following you in the forest. He gleefully related how to split logs with gunpowder. There’s a recipe for stew. An explanation for how to pick a lock with gunpowder and details on how to make a portable woodworking vise (more on that topic some other day).

But not a word on the workbenches. Nothing.

WHY SO QUIET, MR. SPOONWOOD?

There are a few possible explanations for why the codex does not describe the workbenches or vises. Quite possibly, Löffelholz had nothing to say (though he wrote about every other image in the codex in some detail). Another explanation: the pages were lost or removed some time after the codex was written.

The second theory has not been legitimized by any scholar that I know of, but a 1933 essay by Franz M. Feldhaus in "Mitteilungen des Vereins für Geschichte der Stadt Nürnberg" ("News from the Association for the History of the City of Nuremberg") offers an oblique suggestion.

Note that the Rugsamt mentioned below was a jurisdictional court specifically for hearing issues on trade and craft. This essay was also translated by the ever-steady Gøрге.

(W)e know the Council of the City of Nürnberg and the Nürnberger Rugsamt made trade people's lives difficult, because they were eager to hear reports and complaints of envious guild fellows.

This is the reason for a series of significant inventions in Nürnberg, that we have gotten to know of, never having been put into full practice. It would be beyond the scope of this essay to elaborate on these. Suffice it to say that the concept of a modern lathe spinning at high speed has been known to Nürnberg and already implemented centuries ago.

But the Rugsamt, respectively the Council, intervened every time, prohibiting use of such lathes by craftsmen, having the machines crushed or the owner locked up in the tower.

The minutes of such meetings are extremely brief. Only in a few cases it has been possible at all to recognize the technical value of such inventions from Nürnberg. But in the illustrated Löffelholz manuscript we may witness the high technical standard that had been achieved in Nürnberg 425 years ago....

It doesn't take a Fox Mulder to weave a conspiracy theory about the workbench images shown in the codex: Someone redacted the descriptions of the workbenches. The obvious objection to this con-

spiracy theory is, however, this: Why not remove all the pages on the workbenches, including the drawings?

After all, even a half-clever woodworker could build these benches with the drawings alone (as you are about to see).

So after months of effort and lots of dollars flushed down the toilet, I knew exactly as much about this bench as the first time I saw the Löffelholz workbench in a German book while sitting on the bed of a Chicagoland hotel room in the early 2000s.

It was disheartening, but we had explored the text in full. So the only task left was to decode the three drawings in order to bring the Löffelholz workbench to life.

WHO WAS MARTIN LÖFFELHOLZ?

Martin Löffelholz didn't sign his name to the 1505 codex. Instead, his identity was determined by the document's date, the coat of arms on its cover, a genealogical register of patricians from higher nobility and handwriting samples.

The Europeans love their history stuff. It's amateur hour over here on our side of the Atlantic.

As an addendum to Feldhaus's 1933 essay on the codex, Dr. Emil Reicke offered a biographical sketch of Löffelholz, who Reicke characterized as a knight and technician. The following is my attempt to summarize Reicke's account.

We don't know when Löffelholz was born, but his parents were married in 1465. In his youth he left Nürnberg for Bohemia to become an armed cavalier in service of Herr von Tschornhorra.

He shows up in the historical record in 1496 when he participates in a tournament with other knights, including the Margrave Friedrich the Elder. During the tourney, Löffelholz unwittingly unhorsed the Margrave – the Margrave had been in disguise. (Note: This is like trouncing your date at Galaga; no good can come of it.)

Once Löffelholz realized what he had done, he let the Margrave unhorse him later in the tourney and Löffelholz told the Margrave: Wow, you hit me hard.

After sucking up hard to the Margrave, Löffelholz got married a year later to Anna Haug, who belonged to an important family.

They had one child, who died from the plague.

Right after getting married, Löffelholz was named the caretaker of Nürnberg’s Castle Lichtenau near Ansbach. On Christmas Eve in 1507 (two years after starting the codex), Löffelholz rode out to hunt some rabbits.

This was a bad idea. Local Nürnberg council members had warned Löffelholz that things were unsettled in the area (aka, the Margrave was still pissed about being unhorsed) and that perhaps Löffelholz should avoid hunting.

At the time, it was common for people of wealth to be captured and ransomed back to the family for crazy sums of money. And that’s what happened to Löffelholz. Captured by four chevaliers, Löffelholz and his farm hand were taken to Freystadt near Allersberg. The farm hand and the horses were released, but Löffelholz was locked in a vermin-infested tower of Schwarzenburg Castle (no relation, I hope).

The Nürnberg council observed a ban on paying ransoms, even after Löffelholz wrote a pathetic letter about the “uncanny worms” in his tower and how he was locked up by hand and feet. As the hostage situation dragged on, the captors threatened to cut off his hands, feet and all his hair above his ears.

In the meantime, his poor wife tried to make ends meet by renting out the castle at Castle Lichtenau for baby showers, parties and weddings. (Alas, the Nürnberg council shut that down.)

Meanwhile, Löffelholz attempted to escape by stealing a rapier off a guard, hiding it in his clothes then trying to run off after going out for a pee. He failed and was severely wounded during his attempt.

After 60 weeks of confinement, Löffelholz was released when the captors were paid half of what they asked, plus a sum for feeding him for 60 weeks (I know; weird).

When released, he remained the Keeper of Lichtenau for 18 years. His first wife died about 1520; he remarried, then was fired from his job in 1527 due to his “dissolute and inapt nature.” He died in 1533 and was buried at St. Johannis, a district in Nürnberg.

Did he invent the devices in his codex? Scholars can’t say. Many patricians were also inventors. But other scholars, including Feld-

haus, suggest Löffelholz collaborated with the artistic blacksmith Hans Ehmann.

We may never know. But we do know that Löffelholz wrote the words and likely drew the pictures – they are from the same hand and were entered into the codex during a long period of time.

CHAPTER 4

The 1505 Holy Roman Workbench

The 1505 workbench drawn by Martin Löffelholz during the reign of the Holy Roman Empire is separated from the bench at Herculaneum by almost 1,500 years. But the differences between the two seem cosmetic at first.

Both stand on feet that are staked into the benchtop with compound angles to add stability to the bench. Both have holes in the benchtop for workholding devices. Neither has stretchers nor a shelf. But the Löffelholz bench features two stunning details that earn it the title of the first modern workbench (until we find an earlier one, that is).

The bench has a twin-screw face vise on the left side of the benchtop. While this on its own might seem as if it's big news, it's not. Twin-screw vises on the front of a workbench have been around since at least the 14th century.

What's important about this bench is the vise on the right side of the benchtop. It's a screw-driven wagon vise and is indeed a "new thing" for 1505. It's the combination of the twin-screw vise, the wagon vise and a series of holes for dogs that always stuns me.

Throw on a couple stretchers and the bench would be functionally identical to a German workbench from the 19th or 20th century. So the Löffelholz workbench is important because you could easily say it represents the peak of workbench evolution; almost everything else from that point on was a copy, an adaptation or was retrograde.

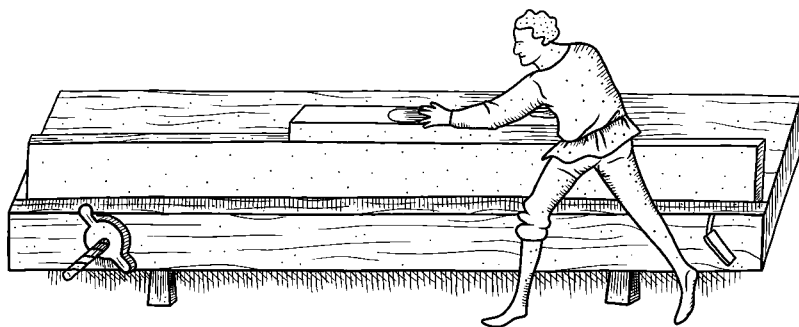

Figure 11: A Northern Italian illustration of the construction of Noah's ark from the early 14th century. Médiathèque d'Arras, ms 252, f.95v.

FIVE SLABS

My bench is built using massive red oak components. The top is 4-1/4" x 19" x 83-1/2". The legs are 5" x 5" x 34". All the parts came to me sopping wet. So wet, in fact, that my moisture meter said they were off the charts (meaning they were 60 percent moisture content or more).

I've long wondered if early bench builders would really wait for a decade for thick components to reach equilibrium. I'm in the middle of a series of experiments in building benches with wet components. This was the first experiment.

If you can use wet wood for a bench, that greatly simplifies things for the would-be builder. You can buy fresh-cut thick slabs (4" to 6" thick) from sawyers and not have to pay to have it kiln-dried (and drying a thick slab correctly is a nearly impossible task for standard

commercial kilns).

So far I can report that there are some challenges to overcome when using wet wood, but it's definitely doable.

The first challenge comes when processing the stock. Unless you have industrial machinery, you are best off using hand tools. Regular home-shop machinery isn't up to the task. The wood is just too thick and wet. I attempted to work on the legs with my 3-horsepower table saw. No luck. The saw froze up immediately. I then tried my 14" band saw, which never stalls. Dead in the water (literally, because the wood was so wet).

Hand tools have no problem; in fact, wet wood is easier to work by hand (in most instances).

So I planed the top and legs to size with a jack. For the benchtop, it's best to four-square the slab because the joinery is measured and marked on the underside of the top.

The legs need to be tapered. They start at 5" x 5" at the feet and taper to 3-3/8" at the top. The jack plane is the tool for this job. It's easier than you think when the wood is wet and you're planing downhill.

The biggest challenge in processing the stock was crosscutting it. The moisture in the wood was not going to give my 8-point hand-saw passage through its fibers. As I began to saw, the wet wood heated up and swelled the kerf shut, grabbing my sawblade like a politician's handshake.

The solution: A jobsite handsaw with induction-hardened teeth. These \$20 saws are deliberately overset. That's annoying when doing nice woodworking in fine hardwoods. But it's exactly what you need when slicing up sopping wet slabs.

LAY OUT THE MORTISES

Use the illustration on the previous page to lay out the location of the mortises and the 62° sightlines on the underside of your benchtop. Set your sliding bevel to 14° off 90° – that's your resultant angle for the legs. Place the bevel on the sightline.

The mortises are 3" in diameter. I used a saw-tooth Forstner bit equipped with a lead screw. This bit, normally used in the construc-

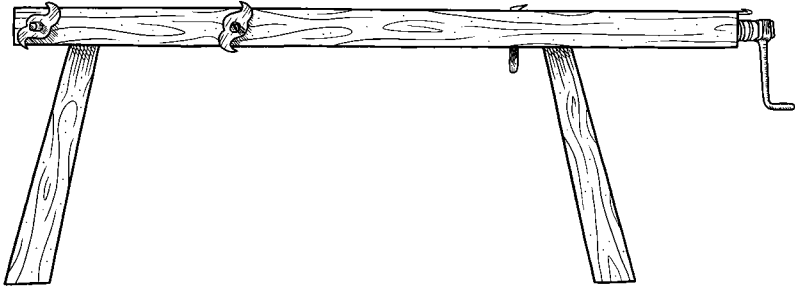

Figure 13: The elevation of the 1505 Holy Roman Empire Workbench.

tion trade, is a bit expensive, but it makes short work of the boring.

To drive the bit, I used a corded drill. And to ensure I drilled at the correct resultant, I had a spotter watch my progress during the boring operation.

This is when I discovered another oddity of sopping wet wood. During the first mortise, the spotter yelled: “Stop. I think the wood is on fire.”

Sure enough there was a plume of smoke rising from the mortise. But it didn’t smell like fire. It smelled like someone had barfed in a Pier 1 store. After pulling the bit out we realized the “smoke” was instead steam. The bit was hot, but it’s difficult to light a swamp on fire.

I drilled on. Also, and though I hate to remind you, don’t forget to clamp a backing board to your work to prevent splintering when your bit forces its way through to the other side.

TENONS

The tenons on the legs are 5" long and are best made on a lathe. I mounted the legs in a midi-lathe (I believe each leg weighed as much as the lathe) and turned the tenons at the slowest speed possible.

If your legs are green wood, I'd turn the tenons to 3-1/8" in diameter. The wood will shrink in short order, especially if you are building the bench in a climate-controlled shop.

If you can, set the legs aside for a week or so to let them calm down a bit. If the tenons are still too big after a week, turn them down until they fit tight into the mortises. The last step before assembly is to kerf each tenon for a wedge. I cut the kerf with a rip saw and sawed just shy of the tenon shoulder.

ASSEMBLY

Putting the bench together is just like assembling a stick chair. Paint the mortise and tenon with hide glue. Drive the leg home – be sure to rotate the leg so the kerf in the tenon is perpendicular to the grain in the benchtop.

Flip the bench over. Take your wedges (my wedges were 4" long and had a 4° included angle at the tip) and paint them with glue. Drive the wedges home and wait for the glue to dry.

After everything is dry, cut down the protruding tenons and plane the top flat. During the next month, keep an eye on the tenons. If they continue to shrink as they dry, drive wedges into any gaps that appear. Everything will settle down within a few months.

THE FACE VISE

The face vise is a fairly standard twin-screw vise with one exception: The vise's jaw is notched into the benchtop instead of being proud of it. I am fairly certain that this example is the only one I know of – though I have no doubt it's been done before.

Which raises the question: Why? My best guess is that it's a way

to conserve wood. If you are careful, you can notch the benchtop and use the off-fall as the jaw.

Having the vise's jaw inset into the front edge presents some difficulties when working. Edge-jointing pieces longer than about 5' is awkward. You can clamp them in the jaw one of two ways: so the excess protrudes off the left side of the bench, or so the excess is elevated over the benchtop.

Both methods work. Having the work suspended over the benchtop has the fun advantage of being able to plane downhill.

The jaw is 1-5/8" wide x 28" long. When you add the screws and vise nuts, you want to end up with about 20" of clamping area between the two screws. That 20" dimension is about as wide a board most people have to dovetail.

The first step is to make the notch and remove the jaw piece from the benchtop. Lay out the rip and the crosscut. I started with the rip cut. After making the 28"-long rip with a rip saw, I clamped the jaw and the benchtop together so the jaw wouldn't splinter off as I finished the crosscut.

Crosscut the jaw free of the benchtop. Clean up the inside of the jaw and the notch in the benchtop with planes and chisels. Try not to remove too much material.

THE VISE SCREWS

I made my own vise screws and vise nuts using hard maple, a fine-grained wood that holds good detail. I made the screws and tapped the nuts with a 28mm German threadbox and tap that's metric. To do the job correctly, you'll also need a 23mm Forstner bit.

Begin by making the screws. Turn down some 12"-long maple sticks to 1.10" (approximately 28mm) in diameter. Leave 2" of each stick square. After turning the sticks, clamp the square section of each stick in a vise and use the threadbox to cut the threads. Keep the threadbox's cutter lubricated with something dense and slippery, such as mutton tallow.

Next bore the 23mm holes in the benchtop. Make them about 4" deep or whatever your bit can handle. Tap the 23mm holes with your tap and clean the debris from the holes. Cut your screws to

final length. You want the screws to protrude about 6" from the jaw.

Carve a little detail on the end of each screw if you like – a little sphere is traditional – then glue the screws into their threaded holes. The fit will be a bit loose. So use epoxy, which will fill the gaps, and clamp the screws so they protrude perpendicularly from the hole.

Check them with a square. Check them again.

The jaw, also called a chop, is easy. Drill 1-1/4"-diameter holes in the chop to clear the vise screws. Apply adhesive cork or suede to the interior of the jaw and the notch to improve its grip.

The vise nuts can be any shape you please. I used 1-1/8" x 3" x 6" scraps of maple. I bored a 23mm hole through the center of each, then shaped the nut like a hurricane on a weather map. This is a traditional shape for the time.

I made several attempts to make the nuts. I twice used geometry and it failed me (too sterile). So I drew the shape of the nuts entirely freehand and those organic nuts were perfectly imperfect.

I cut them out using a coping saw and shaped them with a rasp. Be sure to round over all the edges of the nuts with a rasp. The soft edges are what your fingertips need to operate the vise.

THE END VISE

Löffelholz's drawings for the end vise are a bit of a puzzle. The drawing of the overall bench shows the vise screw suspended without even a vise nut. (It also shows a bench leg sticking right into the vise area.) Perhaps Löffelholz didn't draw the vise nut so you could see clearly that the vise screw was threaded. Perhaps he thought the construction was obvious because of the other drawing dedicated to the end vise.

The end vise drawing shows the vise screw and the moving dog by themselves at the top of the drawing. Below is shown the vise assembled with two additional blocks of wood. At least one of these has to be the tapped vise nut. The second one could be a vise nut or just a bushing that guides the screw and supports the moving dog.

I played around with making both blocks of wood tapped. The complication with that idea was that the blocks had to be precisely

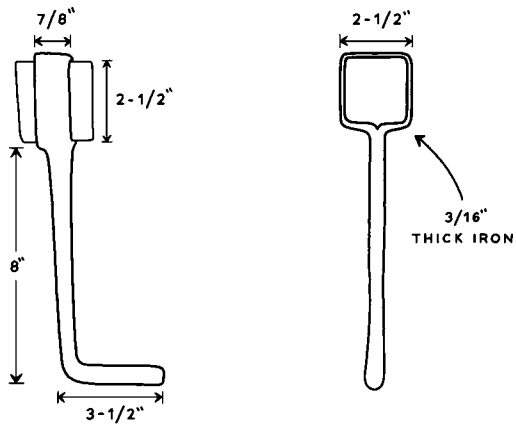
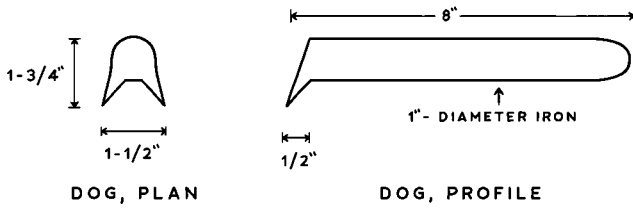
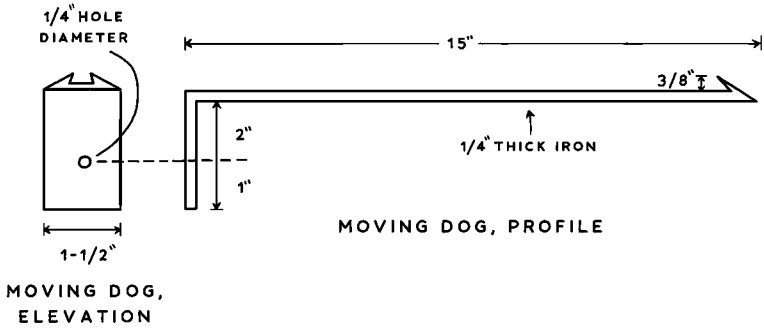

Figure 14: The metalwork for the 1505 Holy Roman Empire Workbench.

located a certain interval from one another or the screw jammed. The much simpler solution was to make one of them a threaded vise nut and the other one a simple bushing.

After some thought, I decided to make the left block as the threaded vise nut; the right one is a simple bushing. The vise would likely work just as well if you reversed their positions.

All this thinking is the easy part. Excavating the cavity for the screw and blocks is a fussy task that took as much time as building the remainder of the bench. You need to keep multiple surfaces in alignment for things to work. I had the further challenge of dealing with a benchtop that was still drying and moving. Anticipating this problem, I made the vise nut somewhat adjustable, and I'm glad I did.

The cavity for the vise screw is 18" long and 3-1/4" wide. I decided on this measurement to accommodate a commercially available 2-1/2"-diameter wooden screw. Lay out this long trench on the benchtop so it begins 3-1/2" from the front edge of the benchtop. Cut the two long walls with a rip saw. To remove the waste between the walls, bore a series of overlapping large-diameter holes at the end of the trench and knock the waste free with a chisel and mallet.

The walls of this trench aren't critical. As long as the vise's screw can pass you're in good shape. So don't bother truing up the walls so they are perfectly parallel to each other and perpendicular to the benchtop.

What is critical is the next step: making the cavities for the vise nut and the bushing.

Begin by making the bushing. It's 1-3/4" x 3-3/4" x 5-1/4" with a hole drilled in its center that allows the vise screw to just pass. Use the bushing to lay out the cavity that will hold it on the end of the benchtop. Use a rip saw – with care – to define the two walls of this cavity. These walls need to be perpendicular to the benchtop and parallel to one another.

To remove the waste, bore what you can then chop the rest with a chisel. Use a square to pare the walls of the cavity so everything is perpendicular to the benchtop. Fit the bushing to the cavity.

Fitting the 2-3/4" x 4" x 5-1/4" vise block is the fussiest part. Use the illustration to lay it out on both the top and the underside of

the benchtop. (Hint: Use the front edge of the benchtop as the reference for your measurements and try squares.) Join the layouts on the benchtop and underside with knife lines across the main trench.

Now it's time to chop. Chop from both sides of the benchtop. I recommend you stay about $1/16$ " away from your layout lines then pare those back to fit your vise block. Note that you need to keep everything square and parallel with the bushing's cavity to get a smooth-turning vise. It's not difficult; it's just tedious.

Ultimately, you want the vise block to fit snugly in its cavity so it can be adjusted up and down with firm mallet taps, like a bench's planing stop. This will give you the adjustment you need as the benchtop dries.

Once you get the vise block fit in its cavity, you can assemble things. Note that part of this equation is the vise hardware. All my hardware was made by blacksmith Peter Ross in North Carolina. It's straightforward stuff that could be made by any talented smith. The details of construction are in the illustration.

No matter who makes your hardware, be prepared to make adjustments to suit the metal. Wood is easier to tweak than iron.

The movable bench dog is secured to the end of the wooden vise screw with a piece of all-thread rod embedded in the end of the vise screw and a couple jam nuts.

Originally I had the blacksmith make a nice dome-head screw to attach the movable dog to the vise screw, but it snapped when I first installed it (my pilot hole was too small – totally my fault). That turned out to be a fortunate accident because using jam nuts makes it easier to remove the moving dog for adjustments.

The all-thread rod is $1/4$ " x 20 that I epoxied into the end of the vise screw. Then I used two $1/4$ " x 20 nuts to lock everything together. The movable dog needs a little slop to work; you'll figure it out.

In the end, here is what you want: The movable dog should rest on top of the vise block and bushing. Nothing except for the vise's teeth should protrude above the benchtop. In my case, I needed to put the vise block and bushing block about $1/4$ " below the benchtop to get things to work.

After lining everything up, I attached the bushing block to the benchtop with 4"-long lag bolts.

For cosmetic reasons, I inlaid a couple strips of 1/4"-thick oak beside the movable dog, closing up the large mortise a bit. These strips also made the vise work a little more smoothly.

The last bit was to add the blacksmith-made crank. This is entirely optional and is a fair amount of work. You could simply use the standard tommy bar that comes with your wooden vise screw.

Instead, I sawed down the hub of the vise screw and fit the collar of the crank around it – just like in the Löffelholz illustrations. Fasten the crank to the vise screw with a countersunk wood screw.

DOG & HOLDFAST HOLES

Drill 1"-diameter dog holes on 3" centers in line with the teeth of your movable dog (this should be about 5-1/8" from the front edge of the benchtop). I also added holdfast holes, though Löffelholz didn't show any on his illustrations.

DETAILS ON USE

If you have used a modern workbench, then most of the controls should feel somewhat familiar, though sometimes you might find yourself reaching for the choke to change the air-fuel mixture.

The face vise feels familiar until you start to edge-joint long boards. As I noted above, things get awkward with long boards because the face vise is inset into the benchtop. For me, the solution was to turn to the end vise and dog. With the bench configured with this end vise, I can clamp boards on edge that are about 73" long.

My bench is low (about 32"), so planing 12"-wide boards on edge with the grip of the teeth is easy.

The end vise was surprising in every way. As it was the first end vise in the historical record (so far), I expected it to be clunky and fussy. In truth, it out-works many modern end vises I have suffered since 1993.

Most end vises have a tendency to lift the work off the bench, which makes planing with them a frustrating exercise. Why do they lift your work off the benchtop? Because the movable dog

mechanism gets saggy. So when you clamp your work the saggy dog starts low then ends up as much as $\frac{1}{4}$ " off the top surface of the benchtop.

This is not a good way to plane stuff.

The Löffelholz vise is like a wagon vise in that it is almost impossible for it to lift the work off the benchtop.

Some people will be put off by the fact that the Löffelholz end vise and dog (I call it the "bitey dog") leave tooth marks in your work. If you build traditional furniture, then you know that these marks are part and parcel when building stuff by hand. Most of us have gotten over it.

If you haven't gotten over it, I recommend you try the vise before condemning it. After about 10 minutes, I was in love. Here's why: Once the teeth of the dogs bite into your work you can do anything. Anything. Really anything. Plane across the grain, what Joseph Moxon calls "traversing." Plane diagonally. Saw across the grain. Plow out dados. Oh, and plane with the grain. This vise will not give up its grip.

Yes, it leaves its mark. But if you are like me, you want to leave your mark, too.

Conclusion

After I put down the morning newspaper, I'm typically on my feet all day until I sit down for dinner with an evening beer.

In my head, sitting down is not working, a lesson that was driven into my skull on the factory floor.

But the low Roman workbench I built for this book has started to change my mind about my long-held attitude toward sitting. Some woodworking operations are easier while on your butt.

I was surprised how easy it is to handplane boards – even long ones – while sitting on the work. Likewise, sawing joints (such as dados) with a carcass saw isn't the contortionist's nightmare I imagined. You simply rotate your torso a bit, and your sawing arm is free of your side-meat.

Of course, the low Roman bench is outstanding when used for ripping and crosscutting stock with full-size saws. And it's a great height for assembling carcasses.

But all this sitting down comes with a trade-off. Ripping tenon cheeks and sawing dovetails requires more stamina than when done at a thigh-high modern workbench because you are both the clamp and the cutter. While using the Roman bench, these two joinery operations reminded me of working on low Japanese trestles where a woodworker has to be both in good shape and highly focused to get the job done.

By the time I cut all my tenon cheeks, I was ready to sit down and cut the joint's shoulders. So like any system that's well-considered, it's a balance.

The Löffelholz workbench had different lessons to teach.

Believe it or not, this bench has the first end vise that I enjoy using. Its toothed dogs hold the work flat to the bench like no other

end vise I've encountered.

Yes, you have to either live with the teeth marks or plan your work around them. (Here's a good example: I used the end vise to clamp chair seats to plane them down. Then I chamfered the underside of the chair seats, removing the bite marks.)

I don't mind the marks much. But some people will.

The face vise offered another great lesson: A simple wooden twin-screw vise is cheap and versatile. If I ever build this workbench again, I'll make the vise jaw proud of the benchtop. But despite this design detail, I've been amazed at how well this diminutive vise can handle almost anything I throw at it.

But the biggest lesson from the Löffelholz was its overall form. When people encounter the Löffelholz bench they usually react one of two ways:

1. That is the weirdest fricking thing I've ever seen made out of wood. What were you smoking/drinking/shooting up when you made it?

2. It's beautiful.

I admit that I went through both of those phases when designing and making the workbench. Many tables from the Middle Ages have this kind of look – tapered square legs that stick out at compound angles.

At first these tables look all the flavors of wrong. There are no aprons. There are no stretchers. The legs taper in the wrong direction. The top is too thick. But once you see hundreds of these tables (usually in manuscripts), they lose their odd aftertaste. That is, until you build one.

After driving the legs home into the benchtop for the first time, I stepped back to look at my work. It looked like I had killed a giant hog that suffered from gout.

I resisted the urge to modernize the legs and tried to stay true to the drawings from the Middle Ages that were stuffed in my clipboard. And I'm glad I did. I cannot imagine this workbench built in any other fashion.

And that brings us to the final lesson, and it's one archaeologists and historians know by heart: Long-dead people were not stupid. Like us, they manipulated the world around them to make their

lives easier. But unlike us, they didn't leave instruction booklets in landfills to let us know how they used their inventions.

So the only way to figure this out is to build the things they painted, engraved or drew – as accurately as possible – and put them to work with an open mind and open heart.

That's the most important lesson I can offer. If you can push back against your biases, if you can resist your urge to modernize something or add a cup holder, you might just discover something old and wondrous.

Christopher Schwarz
Covington, Kentucky
December 2016

Sources

Bauer, Sibylle. "Holzfunde aus sieben Brunnen des Kastellvicus Saalburg - Möglichkeiten und Grenzen Dendroarchäologischer Auswertung." *Saalburg Yearbook* No. 55. (2005). Trans. Gorge Jonuschat. Print.

Blümner, Hugo. *Technologie und Terminologie der Gewerbe und Künste bei Griechen und Römern*. Leipzig and Berlin: B.G. Teubner, 1912. Print.

Feldhaus, Franz M., and Emil Reicke. Essays in *Mitteilungen des Vereins für Geschichte der Stadt Nürnberg*. Trans. Gorge Jonuschat. Nürnberg: J.L. Schrag, 1933. Print.

Goodman, W. L. *The History of Woodworking Tools*. London: G. Bell and Sons Ltd., 1964. Print.

Greber, Josef. *Die Geschichte des Hobels*. Zurich: VSSM, 1956. Print.

Heine, Günther. *Das Werkzeug des Schreiners und Drechslers*. Hannover: Th. Schäfer, 1990. Print.

Killen, Geoffrey. *Egyptian Woodworking and Furniture*. Buckinghamshire: Shire Publications Ltd., 1994. Print.

Löffelholz, Martin. *Löffelholz Codex: Illustrations and descriptions of all kinds of hand tools, torture instruments, hunting devices, weapons ... and other items of entertainment*. Transliteration Dr. Walter Bauern-

feind and Helge Weingärtner. Trans. Göрге Jonuschat. Jagiellonian University, Kraków, Poland. 1505. Print.

Martyn, Thomas, and John Lettice. *The Antiquities of Herculaneum*. London: S. Leacroft, 1773. Print.

Saalburg Yearbook: Report of Saalburg Museum VIII. Trans. Göрге Jonuschat. Frankfurt: F.B. Auffarth, 1934. Print.

Acknowledgments

While this is the shortest book I've yet written, the list of people who helped me research the subjects, translate texts and assist in building the workbenches is embarrassingly long.

This book wouldn't exist if not for the untiring effort of Suzanne Ellison and Göрге Jonuschat, who volunteered hours of digging through old texts, making phone calls to foreign museums and translating much difficult material. All told, the three of us studied thousands of pages of documents to present the 64 pages you hold in your hands.

During the construction process, I leaned heavily on help from Megan Fitzpatrick, who listened patiently to my theories, told me I was full of crap in some cases (much needed!) and gladly helped me leg up both workbenches.

Brian Stuparyk at Steam Whistle Letterpress was crazy enough to agree to print this book on his Vandercook 425 proofing press in Newport, Ky. And artist Nicholas Moegly provided the beautiful illustrations based on the cave scratchings I gave him to work with.

Wesley Tanner is the bird on my shoulder when it comes to page design, and the crisp title page and the appropriate font in this book are because of his influence.

Blacksmith Peter Ross is always willing to make odd bits of metal for me, and his work is essential to mine. And Will Myers helped me get the wood I needed when I came up empty-handed locally.

And, of course, my wife, Lucy May, is the reason I can write and publish books. If not for her support, I'd still be a reporter at some daily newspaper writing about the day's trailer fire. (Note: That's not a bad life – I adore a good trailer fire – but this life is better.)